

DOING BUSINESS IN NORTH AMERICA

**Defence + Industry Conference
28Jun 2011**

David Marshall, Minister-Counsellor
Defence Materiel
Washington, DC



Source: President's Budget Historical Tables and FY2010 Appropriations Acts

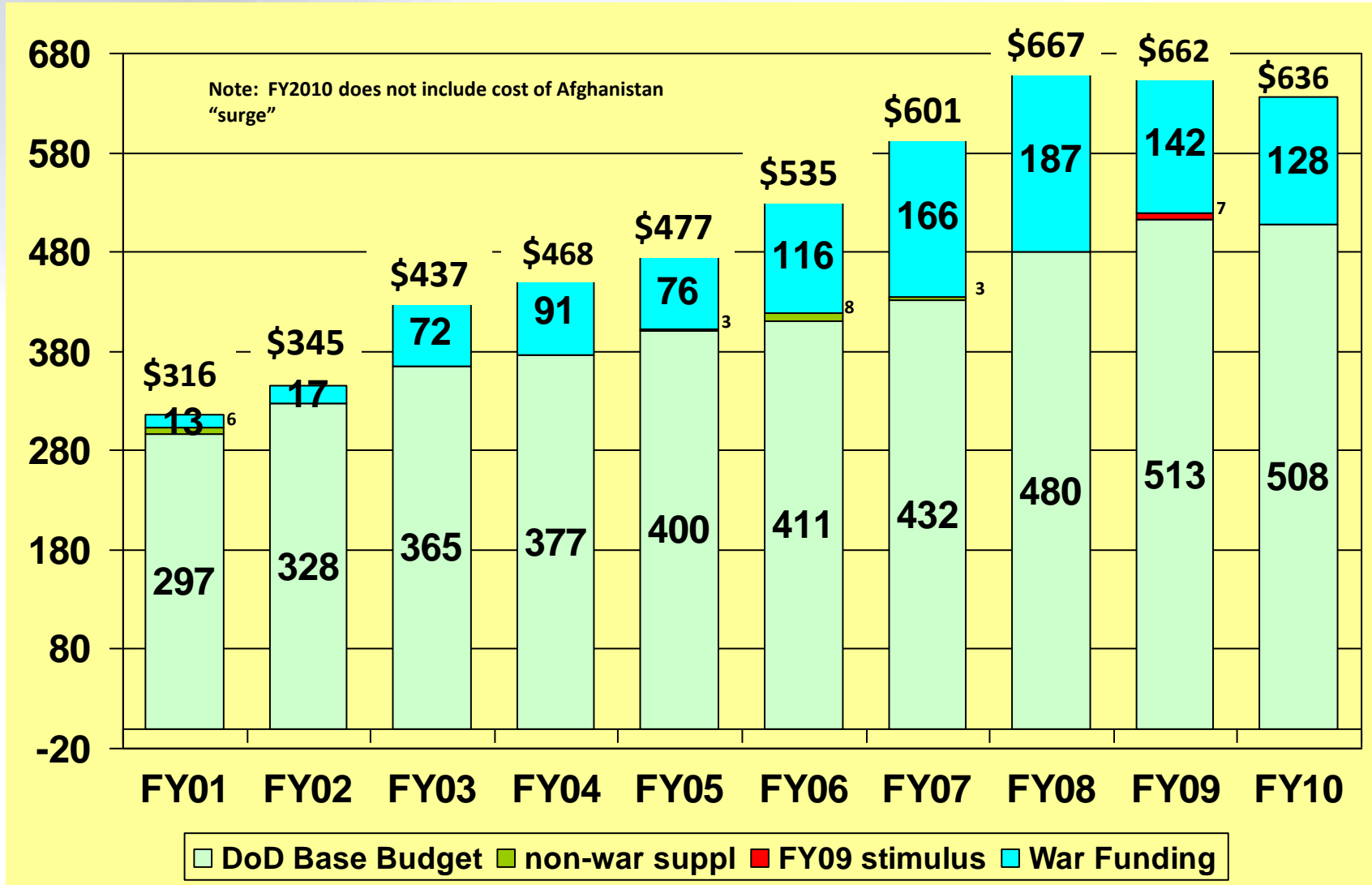

DoD Budget Authority \$ billions

	FY 2008 actual	FY 2009 estimate	FY 2010 Appropriated
Military Personnel	\$ 139.0	\$ 148.5	\$ 139.2
Operations & Maintenance	256.7	272.4	263.6
Procurement	164.9	135.6	127.5
RDT&E	79.6	81.0	80.8
MILCON	22.1	26.8	23.3
Family Housing	2.9	3.8	2.3
Other	9.9	1.1	1.9
Total DoD	\$ 674.7	\$ 663.7	\$ 636.3

FY2008 includes basic appropriation plus enacted supplementals of \$87 billion and \$100 billion.

FY2009 includes basic appropriation plus enacted war funding of \$66 billion and Suppl of \$77 billion.

FY2010 includes basic appropriation plus Overseas Contingency Operations appropriation

Other - includes accrual payments to military retirement fund, some minor mandatory payments in various appropriations, and offsetting receipts.

Numbers may not add due to rounding

Sources: FY2010 Presidents Budget Historical Data; FY2010 Appropriations

Procurement & RDT&E Budget Authority 2000-2010

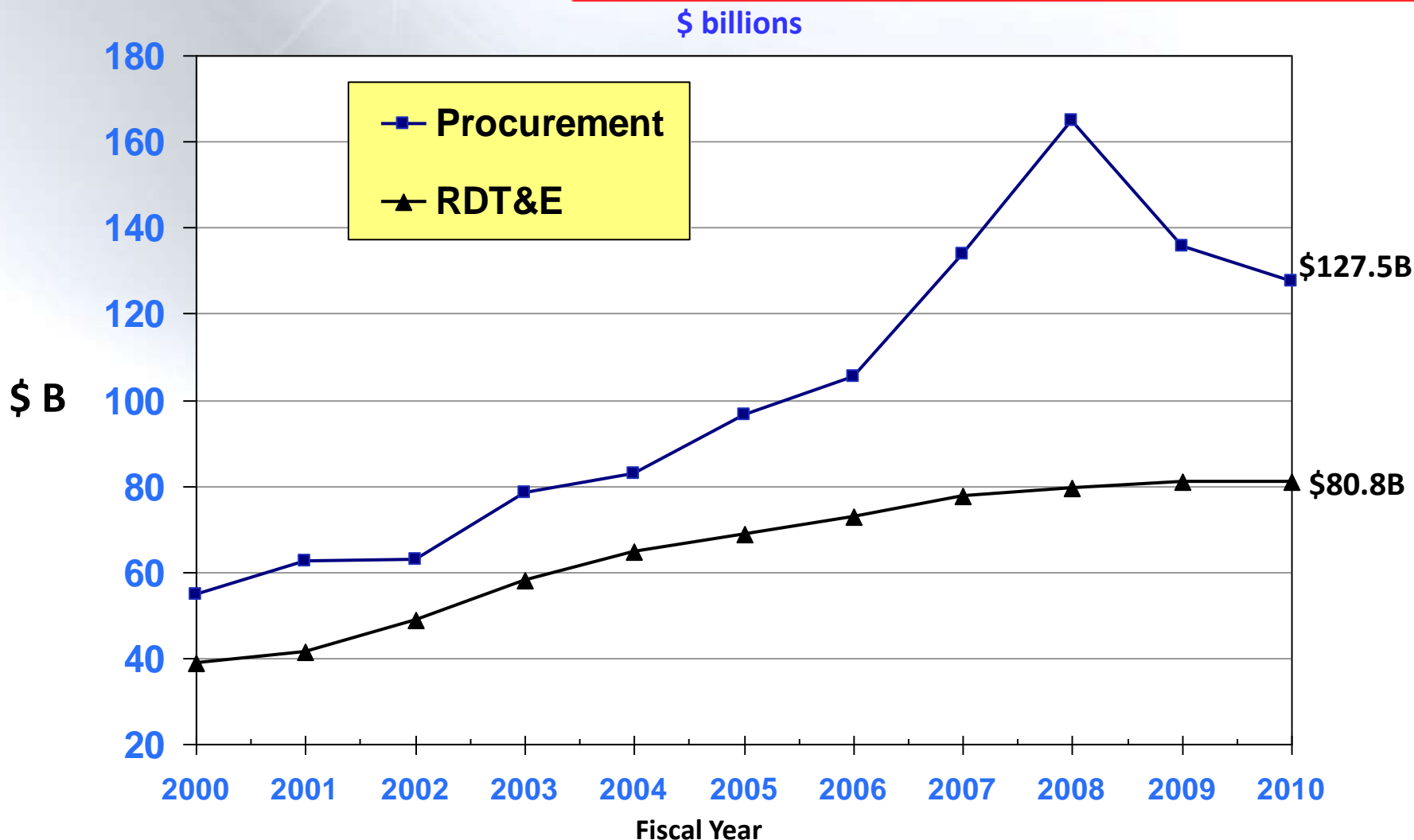

Includes base + supplementals through 2009; base + OCO for FY2010

Sources: FY2010 Presidents Budget Historical Data; FY2010 Appropriations

DMO

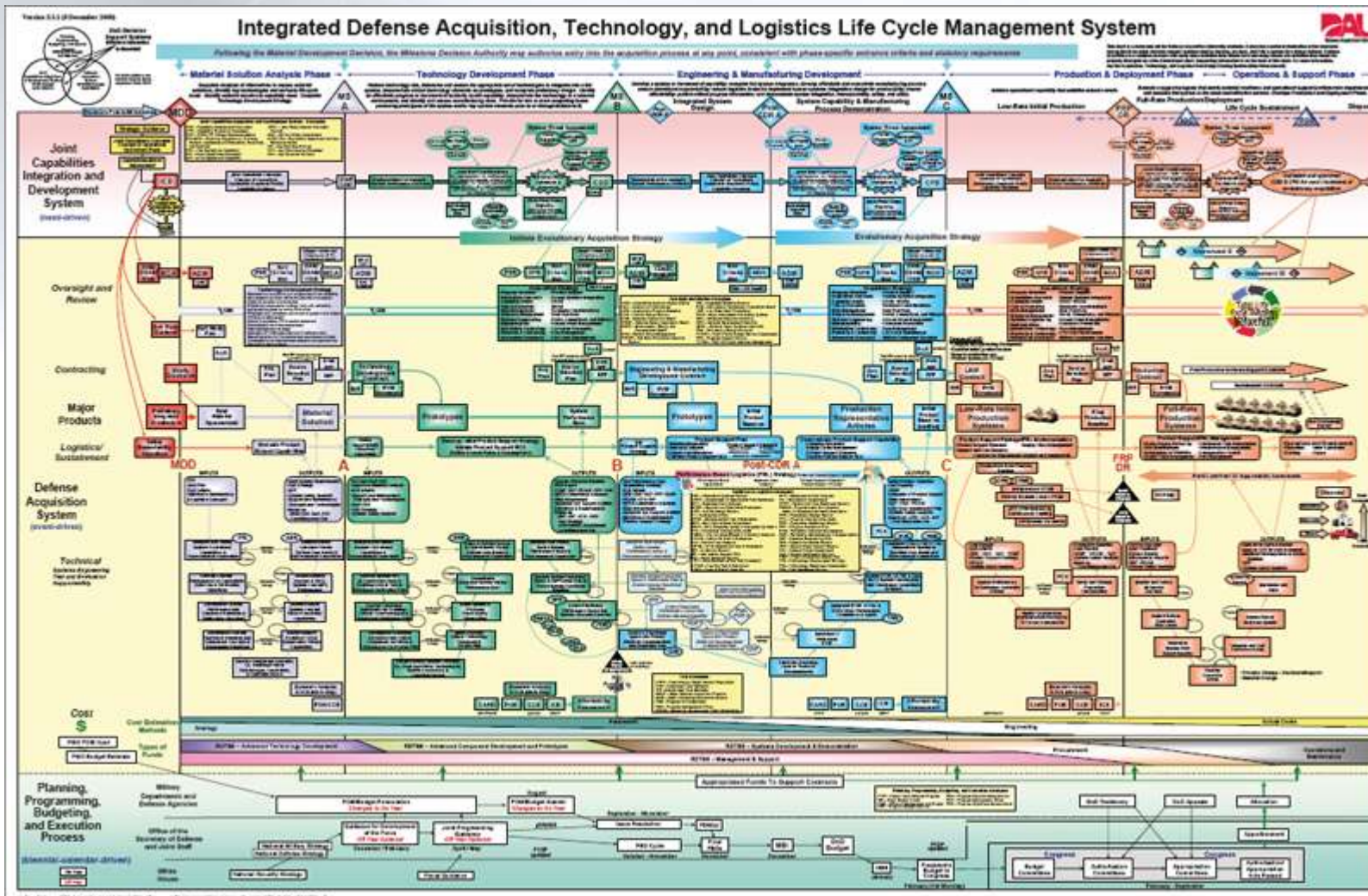

FEB MAR APR MAY JUN JUL AUG SEPT OCT

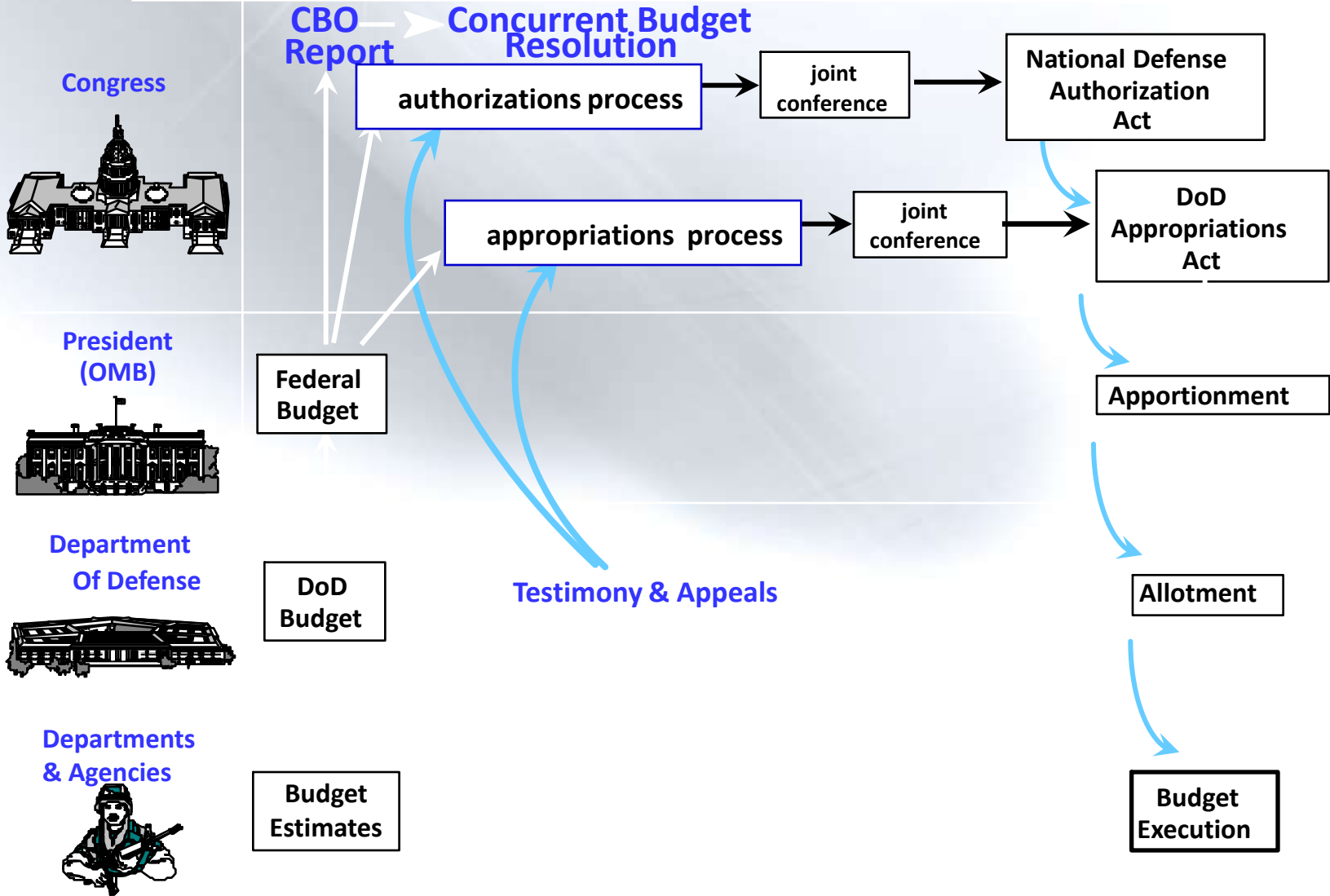

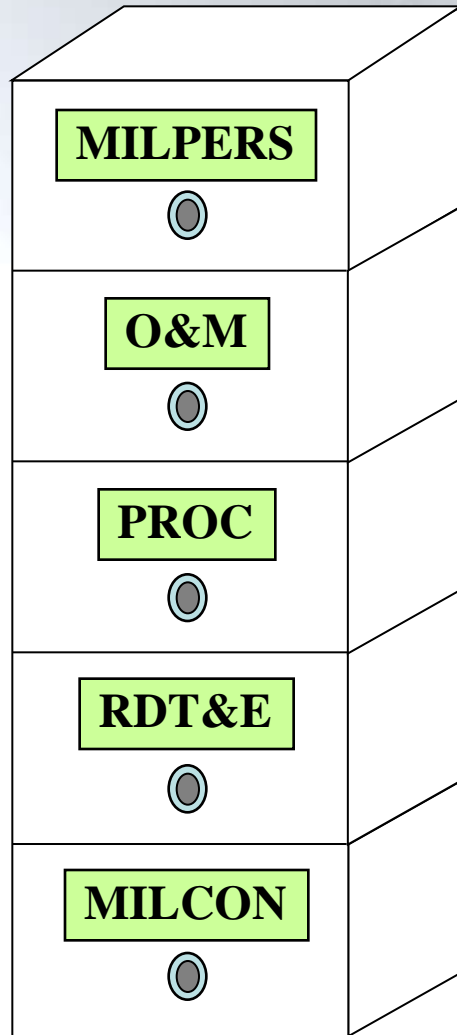

Military Personnel (MILPERS)

Active & Reserve Forces

Operation & Maintenance (O&M)

Active & Reserve Forces

(civilian Salaries, supplies,
spares, fuels, travel, etc...)

Environmental Restoration
Former Soviet Union Threat
Reduction
Overseas Humanitarian,
Disaster, & Civic Aid

Procurement

Aircraft
Missiles
Weapons
Weapons & Tracked Combat
Vehicles
Ammunition
Other Procurement
Shipbuilding & Conversion
Marine Corps
Defense wide procurement
National Guard & Reserves

Research, Development, Test & Evaluation (RDT&E)

Basic Research

Applied Research

Advanced Technology Development
Advanced Component Development
& Prototypes

System Development & Demonstration
RDT&E Management Support
Operational Systems Development

Military Construction (MILCON)

Facilities

Family Housing

Base Realignment & Closure (BRAC)

Other

Defense Health Program

Chemical Agents & Munitions
Destruction

Drug Interdiction & Counter-Drug
Activities

Joint Improvised Explosive Device
Defeat Fund

Rapid Acquisition Fund

Office of the Inspector General

<p>Major Defense Acq Programs (MDAP)</p>	<p>ACAT ID:</p>	<ul style="list-style-type: none"> • DAB review • Designated by USD(AT&L) • Decision by USD(AT&L) 	<p>\$365M RDT&E or \$2.19B Procurement (FY2000 Constant \$)</p>
	<p>ACAT IC:</p>	<ul style="list-style-type: none"> • Component review • Designated by USD(AT&L) • Decision by Component Head/CAE 	
<p>Major AIS Acq Programs (MAIS)</p>	<p>ACAT IAM:</p>	<ul style="list-style-type: none"> • ITAB review • Designated by USD(AT&L) or ASD(NII)* • Decision by USD(AT&L) or designee* 	<p>\$378M Life Cycle Cost or \$126M Total Prog. Cost or \$32M Prog. Cost in any single year (FY2000 Constant \$)</p>
	<p>ACAT IAC:</p>	<ul style="list-style-type: none"> • Component review • Designated by USD(AT&L) or ASD(NII)* • Decision made by Component Head/CAE 	
<p>Major Systems</p>	<p>ACAT II:</p>	<ul style="list-style-type: none"> • Does not meet ACAT I Criteria • Designated by Component Head/CAE • Decision by CAE or as designed by CAE 	<p>\$140M RDT&E or \$660M Procurement (FY2000 Constant \$)</p>
<p>all other programs (except for Navy & USMC)</p>	<p>ACAT III:</p>	<ul style="list-style-type: none"> • Does not meet ACAT I, IA or II Criteria • Designated IAW Component policy • Decision at lowest appropriate Level 	<p>No Fiscal Criteria</p>
<p>Navy USMC</p>	<p>ACAT IV:</p>	<ul style="list-style-type: none"> • Not otherwise designated ACAT I, IA, II or III • Designated IAW SECNAV policy • Decision at lowest appropriate level 	<p>SECNAVINST 5000.2 (Navy and Marine Corps)</p>

*ASD(NII) when delegated by USD(AT&L)

US DoD Likes Competition

USD (AT&L) Dr Carter spoke at the Cowen Investment Conference, on “The Defense Industry Enters a New Era”. [9FEB11]

The Seven Guideposts DoD Will follow in considering industry structure are;

- Reliant on market forces to make efficient adjustments to the Defense Industrial Base,
- Competition is one of the Key Drivers,**
- Seek to sustain the health, vibrancy & efficiency of the industrial base & will conduct a sector by sector review,
- Note the industrial base is not just the Primes, lower tiers are rich in innovation & drivers of costs & supply chain efficiency,**
- Give heightened attention to services component of goods & services,
- Encourage new entrants, lower the barriers to entry,**
- Committed to continue to open markets, better utilisation of “non heritage” firms.**

Some options to pursue to win Business;

- Product considered under the Foreign Comparative Test (FCT) Program.
- Participate in DEU supported Trade Missions
 - Aug 15-18th Veteran & Small Business Conf & Expo
 - Sep 27-29th Modern Day Marine (MDM)
 - Oct 10-12th Association of the United States Army (AUSA)
 - Nov 28th-1Dec Interservice/Industry Training, Simulation & Education Conf (I/ITSEC)
- Through Australian Acquisitions
 - Australian Industry Capability (AIC)
 - Global Supply Chain (GSC)
- Focused Individual Company Support
- Overseas Company Inward Investment (with Austrade)

The Foreign Comparative Test Program

www.acq.osd.mil/cto

Program's objectives are to improve the U.S. warfighter's capabilities and reduce expenditures through:

- Rapidly fielding quality military equipment.
 - Eliminating unnecessary duplication of research, development, test, and evaluation.
 - Reducing life cycle or procurement costs.
 - Enhancing standardization and interoperability.
 - Promoting competition by qualifying alternative sources.
 - Improving the U.S. military industrial base.
- Funds T&E of Foreign product to demonstrate potential to satisfy a DoD requirement.

CTO Has been successful for Australian Companies The Results

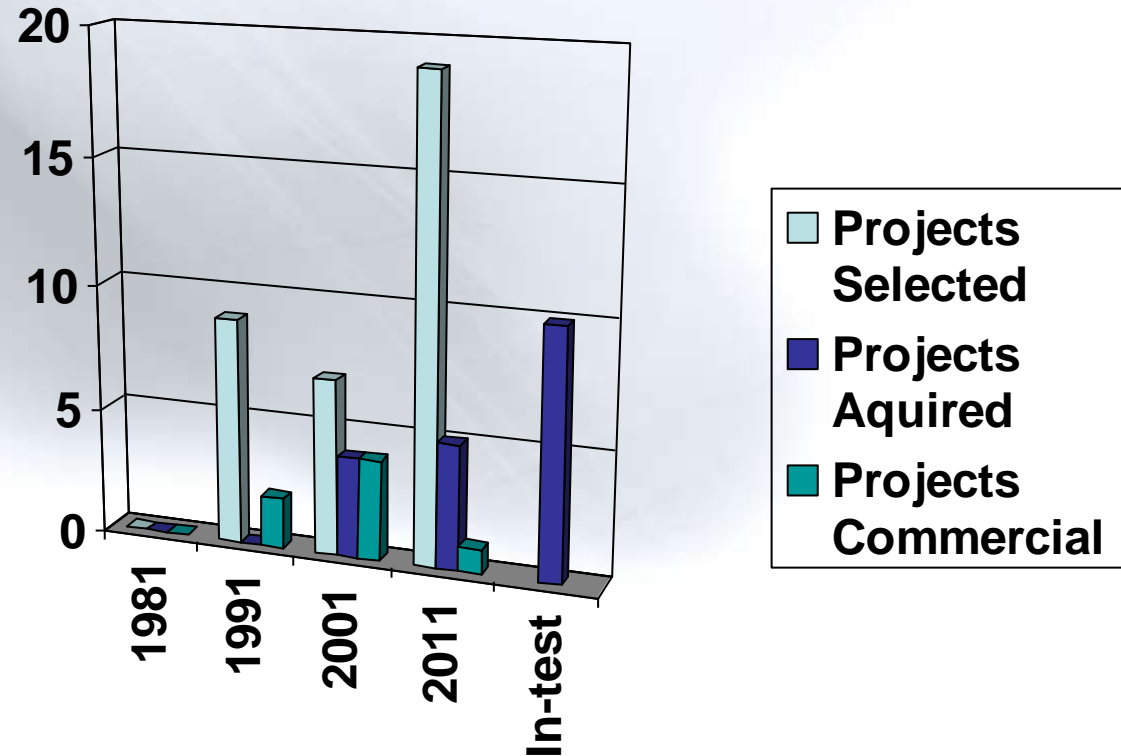

- Note- 1) 10 Projects are still in Test as of 2010
2) Anticipate 7 will lead to DoD Acquisition, and
3 to Commercial arrangements

- 36 CTO Project Selections over 33 years
- Sales by Australian Firms of more than \$415.5 Million- US Department of Defense only (Does not Include 3rd Country Sales or commercial purchases)
- Expanded Markets for Australian Firms worldwide
- Influenced/Overcame “NIH” for Other Australian Products
- Acquired by US DoD (i.e., NULKA, FastShips- Ferries and LCS)

Team Australia” Events 2011

National Veterans’ Small Business Conference August
Convention Center, New Orleans, Louisiana

Modern Day Marine (MDM) – September 27-29, 2011 Marine
Corps Base, Quantico, Virginia

Security Focused Mission to Special Operations Command-
Tampa, Florida week of 3 October 2011(in planning)

Association of the US Army (AUSA) – Oct 10-12, 2011
Convention Center, Washington, DC

**Interservice/Integrated Training and Simulation Exhibition
and Conference (I/ITSEC)-** 28 Nov- 1 Dec 2011, Convention
Center Orlando, Florida

Note: Other Missions may be scheduled by DEU as appropriate

Service Disabled Veteran-Owned Small Business Procurement (SDVOSB) Program

- Policy. Heads of agencies shall provide the opportunity for service-disabled veteran businesses to significantly increase the Federal contracting and subcontracting of such businesses.
- Law. Sec 15(g) of the Small Business Act (15 U.S.C. 644(g)), which provides that the President must establish a goal of not less than **3 percent** for participation by service-disabled veteran businesses in Federal contracting, and
- Sec 36 of that Act (15 U.S.C. 657f), which gives agency contracting officers the authority to **reserve** certain procurements for service-disabled veteran businesses. [Executive Order Oct 2004]
- <http://www.ssa.gov/oag/sdvosb/executive%20order.pdf>
- <http://www.acq.osd.mil/dpap/policy/policyvault/2007-0828-DPAP.pdf>

Women-Owned Small Business (WOSB) program

- On January 31, 2011, The Small Business Administration (SBA) announced the new Women-Owned Small Business (WOSB) program is effective February 4, 2011
- This program allows the acquisition workforce to set aside requirements for WOSBs in order to help us meet the statutory goal of 5% of federal contract dollars being awarded to WOSBs
- US Small Business Administration <http://www.sba.gov/>

Question Time

